

44-2200 Series

Regulators - Pressure Reducing

D44221731X012

Specifications

For other materials or modifications, please consult TESCOM.

OPERATING PARAMETERS

Pressure rating per criteria of ANSI/ASME B31.3

Maximum Inlet Pressure

400, 3500 psig
27.6, 241 bar

Outlet Pressure Ranges

0-25, 0-50, 0-100, 0-250, 0-500 psig
0-1.7, 0-3.4, 0-6.9, 0-17.2, 0-34.5 bar

Design Proof Pressure

150% maximum rated

Leakage

Internal: Bubble-tight

External: Design to meet $\leq 2 \times 10^{-8}$ atm cc/sec He

Operating Temperature

-40°F to 165°F / -40°C to 74°C

Flow Capacity

3500 psig / 241 bar Inlet: $C_v = 0.06$

400 psig / 27.6 bar Inlet: $C_v = 0.15$

Maximum Operating Torque

30 in-lbs / 3.4 N•m

Decaying Inlet Characteristic

$C_v = 0.15$

1.2 psig / 100 psig

0.08 bar / 6.9 bar

$C_v = 0.06$

0.75 psig / 100 psig

0.05 bar / 6.9 bar

MEDIA CONTACT MATERIALS

Body

316L Stainless Steel, Brass, Hastelloy®* or Monel

Bonnet

300 Series Stainless Steel, Brass

Diaphragm

316 Stainless Steel, Elgiloy®

Seat

Teflon®

Remaining Parts

316 Stainless Steel, Brass, Hastelloy®* or Monel

OTHER

Cleaning

CGA 4.1 and ASTM G93

Internal Volume

6 cc

Weight (without gauges)

2 lbs / 0.9 kg

Teflon® is a registered trademark of E.I. du Pont de Nemours and Company.

Hastelloy® is a registered trademark of Haynes International, Inc.

Elgiloy® is a registered trademark of Elgiloy Corp.

*Material to be Hastelloy® or equivalent per ASTM B 574



TESCOM 44-2200 Series is a compact, lightweight high purity single-stage regulator for specialty, flammable, and industrial gas flows of less than 5 SCFM / 141 SLPM. Its diffusion-resistant metal diaphragm seal ensures gas purity and integrity.

Applications

- Laboratory and point-of-use gas systems
- Sampling systems, zero, span and calibration analyzer gases
- Specialty and industrial gas cylinder regulator
- Chromatograph flame detector fuel supply

Features and Benefits

- Compact
- Designed to minimize contamination and provide accurate regulation of any corrosive, non-corrosive, or toxic gas
- Brass model provides added economy for control of non-corrosive media
- Metal-to-metal diaphragm to body seal ensures minimum inboard and outboard leakage
- Convoluted diaphragm delivers excellent accuracy and long service life
- Panel mounting is available
- 300 Series Stainless Steel or Brass bonnet
- NACE compliant designs are available

44-2200 Series Regulator Drawing

PORTING CONFIGURATION

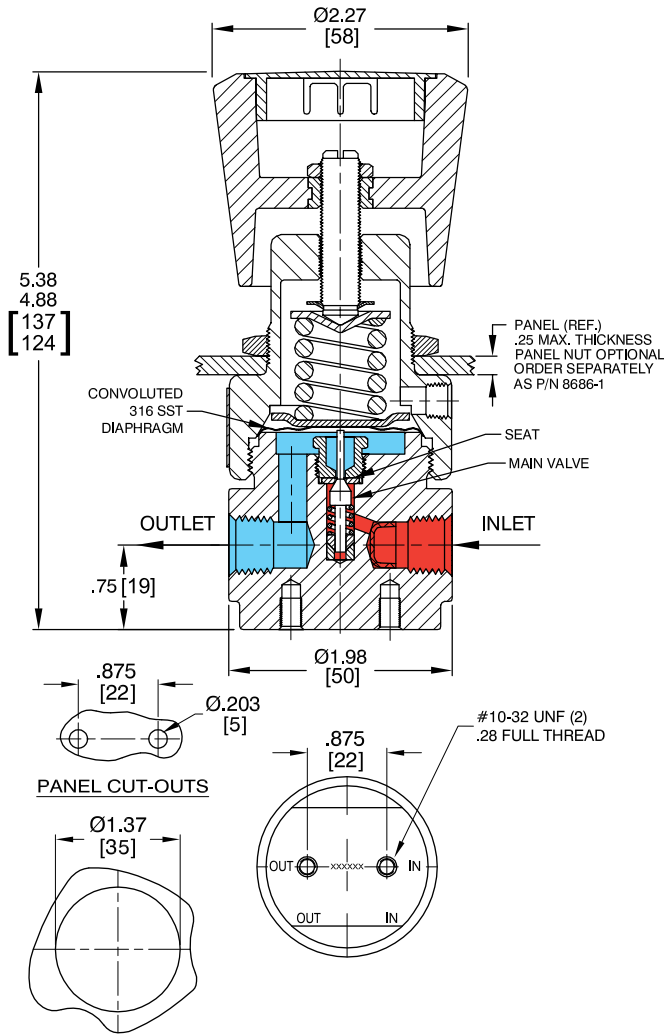
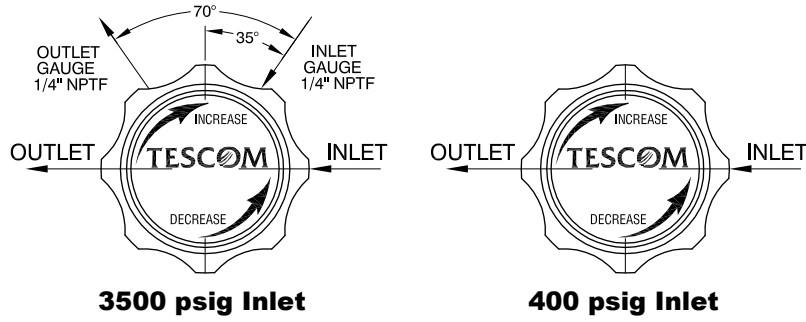

All dimensions are reference & nominal
Metric [millimeter] equivalents are in brackets

44-2200 Series Regulator Flow Charts

For more information on how to read flow curves, please refer to the Flow Curves and Calculations document (debul2007x012) in the TESCOM catalog or on www.tescom.com.

