

SG3 Series

Regulators - Pressure Reducing

DSG032033X012

Specifications

For questions about this product, please consult TESCOM.

OPERATING PARAMETERS

Pressure rating per criteria of CGA E-4; ASME B31; ASME BPVC

Maximum Inlet Pressure

4500 psig / 310 bar

Maximum Outlet Pressure

15, 50, 125, 250 psig
103, 345, 862, 1724 kPa
1.0, 3.4, 8.6, 17.2 bar

Design Proof Pressure

150% of rated pressure

Leakage

Internal: Bubble-tight

External: Designed to meet $< 2 \times 10^{-8}$ atm cc/sec He

Operating Temperature

-40°F to 140°F / -40°C to 60°C

Flow Capacity

$C_v = 1.0$

Decaying Inlet Characteristic

For Stainless Steel

0.8 psig / 100 psig
0.06 bar / 6.9 bar

For Neoprene Diaphragm

0.49 psig / 100 psig
0.03 bar / 6.9 bar



TESCOM SG3 Series is a compact, lightweight, high purity single-stage regulator for specialty, flammable and industrial gas flows of 5-200 SCFM / 141-5600 SLPM. Sensitive, extra long-life metal diaphragm ensures gas purity and integrity. Exceptionally low decaying inlet characteristic provides a stable outlet pressure as inlet pressure varies. User-friendly model number enables the specifier to select optional gauges, relief and shut-off valves and cylinder connections as part of the regulator assembly.

MEDIA CONTACT MATERIALS

Body

Stainless Steel, Plated Brass

Seat

PCTFE

Diaphragm

316 Stainless Steel or neoprene

Filter

10 micron nominal sintered Bronze
10 micron nominal sintered 316 Stainless Steel
or 316L Stainless Steel

Seal

Teflon® or Buna-N

Remaining Parts

Brass, 300 Series Stainless Steel

Applications

- Laboratory and Point-of-Use Gas Systems in medical, pharmaceutical, food and beverage and other high purity applications
- High flow, high purity air (CDA and APR) in semiconductor and biotech facilities

Features and Benefits

- Optional neoprene diaphragm provides exceptional sensitivity for precise pressure control
- Cartridge valve design incorporates 10 micron filter to protect the regulator seat and makes service simple

OTHERS

Connections

Inlet and outlet: 1/2" NPTF
Accessories: 1/4" NPTF

Cleaning

CGA 4.1 and ASTM G93

Weight

5.5 lbs / 2.5 kg

Teflon® is a registered trademark of E.I. du Pont de Nemours and Company.

SG3 Series Regulator Drawing

5 Ports
(Top view)

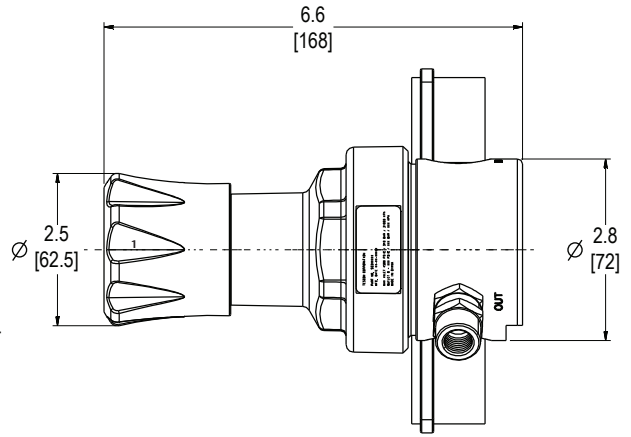
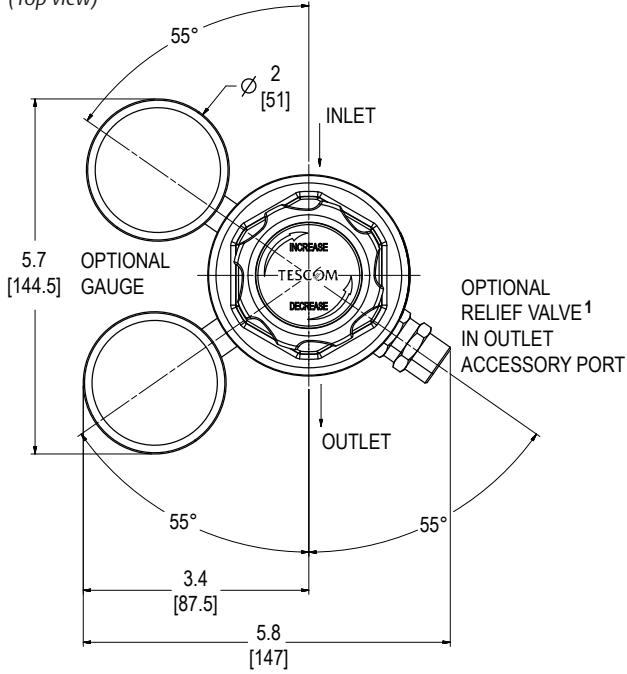

4 Ports
(Top view)

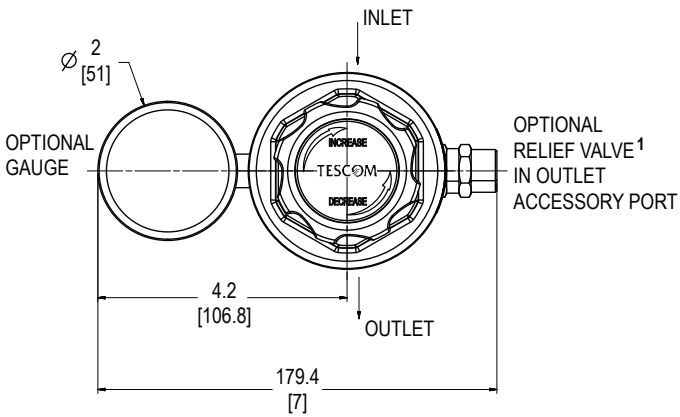

Bottom Mounting

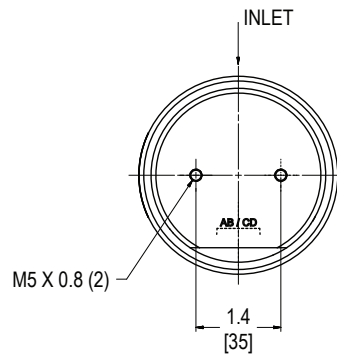

All dimensions are reference & nominal
Metric [millimeter] equivalents are in brackets

SG3 Series Regulator Flow Charts

For more information on how to read flow curves, please refer to the Flow Curves and Calculations document (debul2007x012) in the TESCOM catalog or on www.tescom.com.

$C_v = 1.0$ Model

Metal Diaphragm

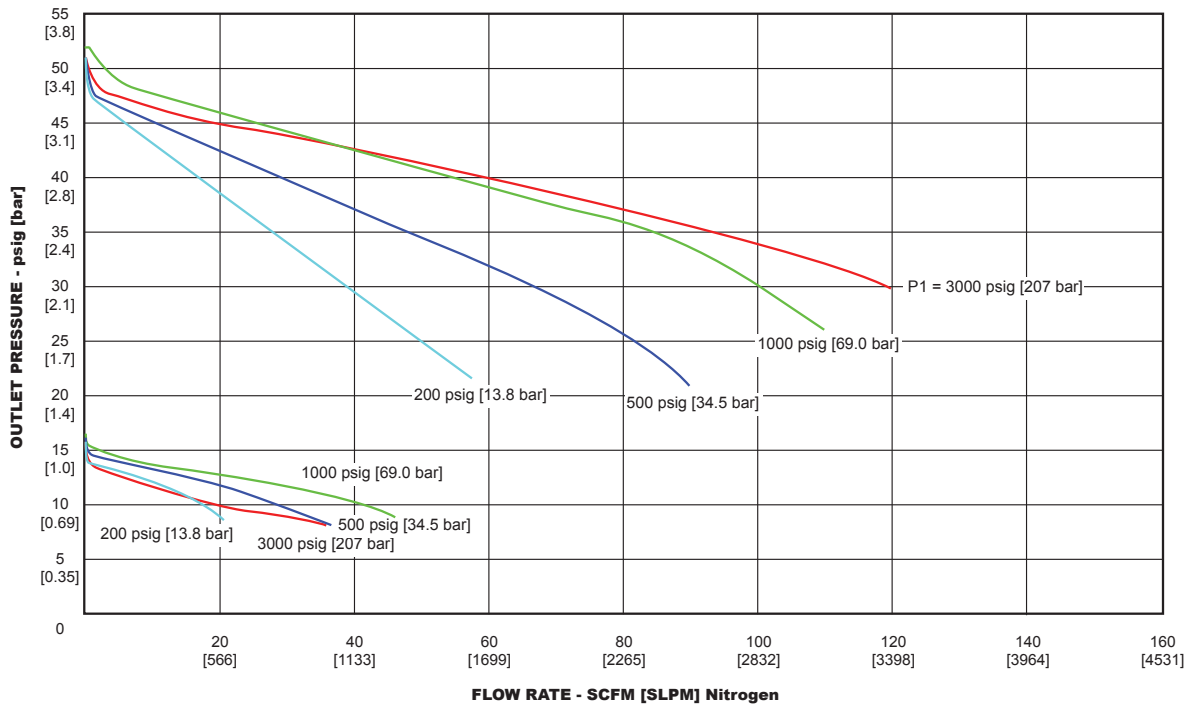
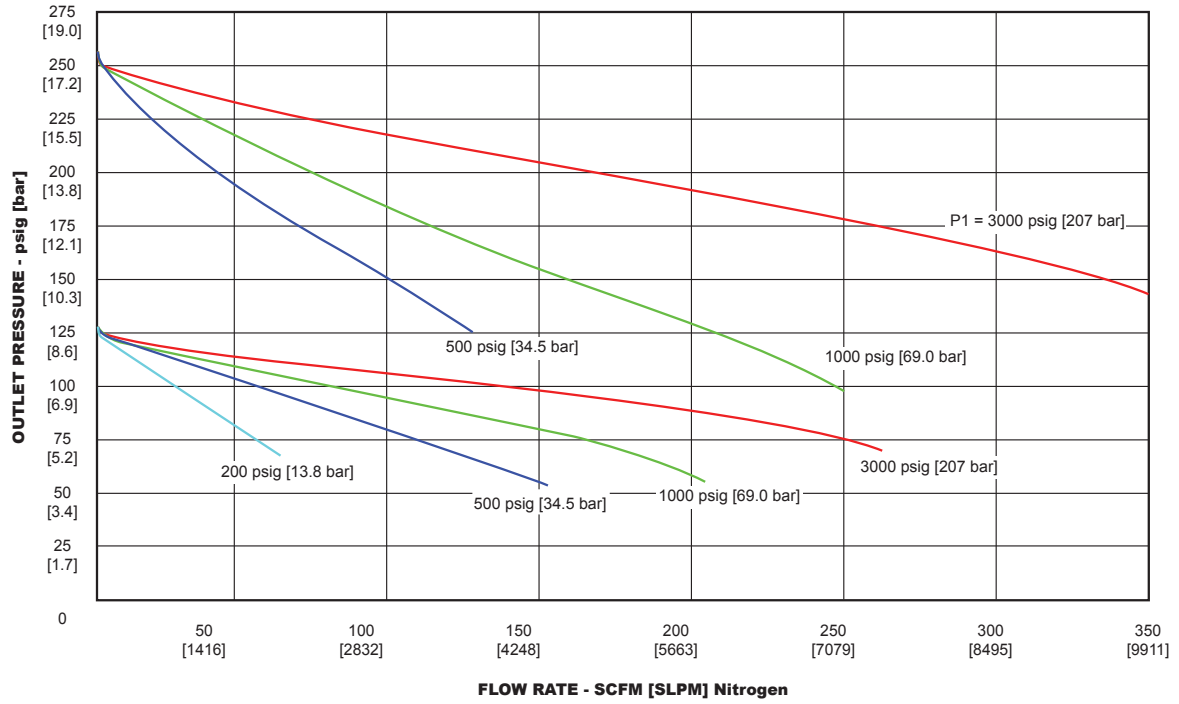

SG3 Series Regulator Flow Charts

For more information on how to read flow curves, please refer to the Flow Curves and Calculations document (debul2007x012) in the TESCOM catalog or on www.tescom.com.

C_v = 1.0 Model

Neoprene Diaphragm

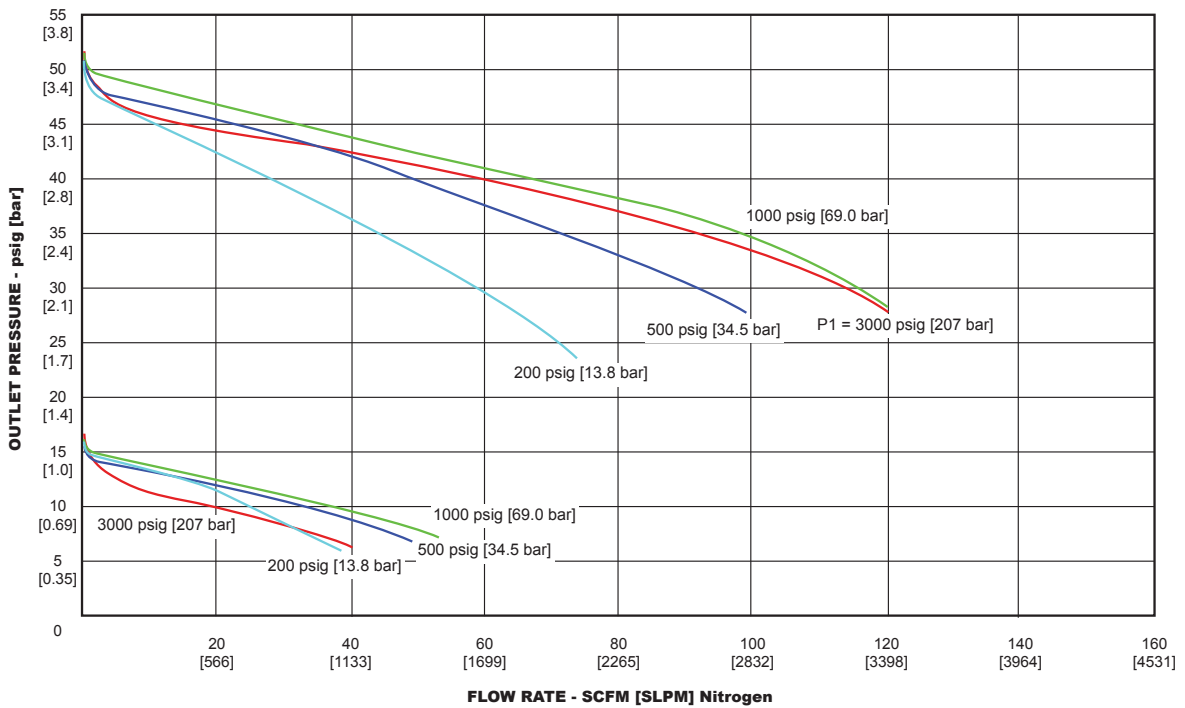
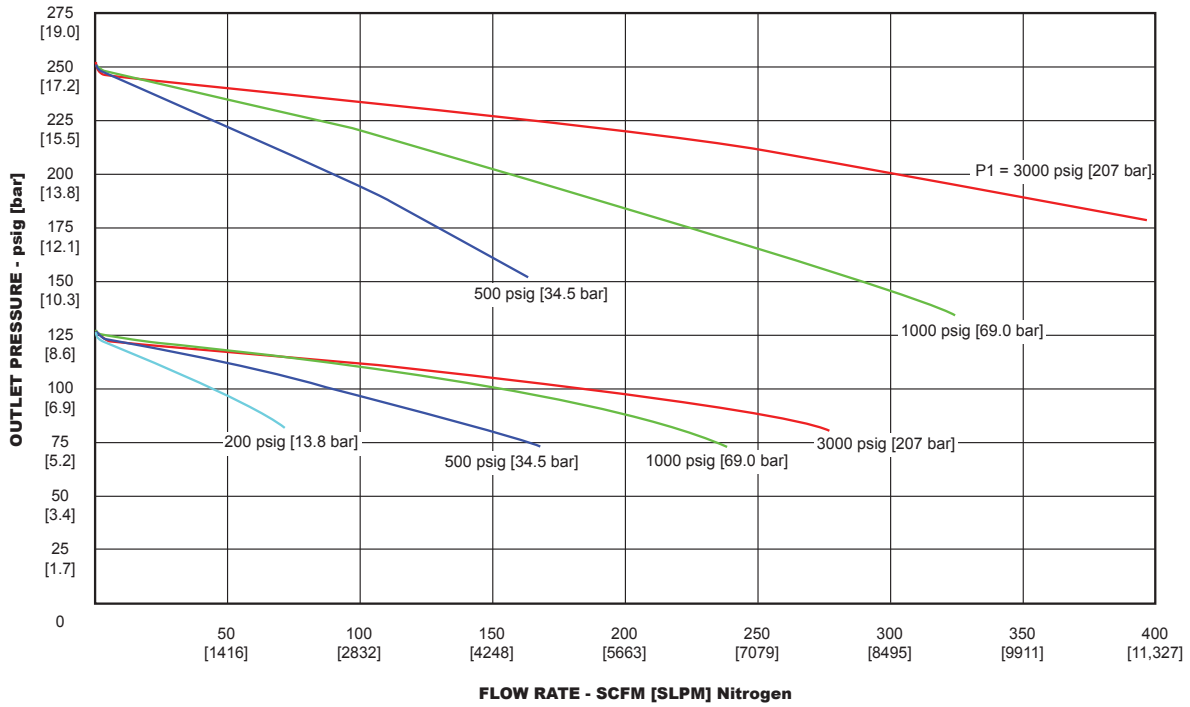

SG3 Series Regulator Part Number Selector

Repair Kits, Accessories & Modifications may be available for this product. Please contact TESCOM for more information.

Base Model

Example for selecting a part number:

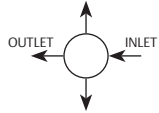
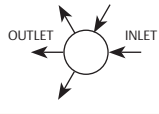
SG3	6	3	1	4	0	
BASIC SERIES	BODY MATERIAL	OUTLET PRESSURE RANGES	DIAPHRAGM MATERIAL	SEAL MATERIAL	PORTS ² (TOP VIEW)	C _v
SG3	P – Plated Brass 6 – Stainless Steel	1 – 15 psig / 103 kPa / 1.0 bar 3 – 50 psig / 345 kPa / 3.5 bar 4 – 125 psig / 862 kPa / 8.6 bar 5 – 250 psig / 1724 kPa / 17.2 bar	1 – Stainless Steel 2 – Neoprene	Teflon® Buna-N	4 – 4 port  5 – 5 port 	0 – 1.0

Accessories

Extension to base model part number:

SG3XXXXX – 0 0 A 1 0

BASE MODEL NUMBER

GAUGES ²	RELIEF VALVE ¹
0 – None P – Plug(s) A – psi / kPa B – bar / psi	A – None P – Plug 1 – Teflon® Pipe-away

¹ The relief valve is not intended to be a "Pressure Relief Device" as defined by ASME Boiler & Pressure Vessel Code - Section VIII, nor is it intended to be a "Safety Accessory" or "Pressure Limiting Device" as defined by the Pressure Equipment Directive (97/23/EC). The relief valve is intended to indicate a potential problem with the regulator and prevent further damage to the regulator. The relief valve is not intended to protect the downstream process equipment.

²GAUGE PRESSURE RANGES

OUTLET PRESSURE RANGE	OUTLET GAUGE PRESSURE RANGE
SG3X1XXX – 15 psig / 103 kPa / 1.0 bar	0-30 psig / 200 kpa / 2 bar
SG3X3XXX – 50 psig / 345 kPa / 3.4 bar	0-60 psig / 400 kpa / 4 bar
SG3X4XXX – 125 psig / 862 kPa / 8.6 bar	0-160 psig / 1100 kpa / 11 bar
SG3X5XXX – 250 psig / 1724 kPa / 17.2 bar	0-300 psig / 2000 kpa / 20 bar
INLET PRESSURE RANGE	INLET GAUGE PRESSURE RANGE
All	6000 psig / 41,000 kpa / 400 bar

SG3 Series Rebuild Kits

Rebuild Kits include replacement cartridges, diaphragms, diaphragm seals and instruction sheet.

KIT PART NUMBER	FOR SG PART NUMBER
JT389-8939	SG3PX1X0
JT389-8940	SG3PX2X0
JT389-8941	SG36X1X0
JT389-8942	SG36X2X0