

# Pressure Control Valves

## Pressure Reducing Valves DM 586

Millibar Control Valve for High Flow Rates



### Technical Data

Connection DN	20 - 50
Connection G	3/4 - 2
Nominal Pressure PN	16
Inlet Pressure	up to 16 bar
Outlet Pressure	0,008 - 0,96 bar
K <sub>vs</sub> -Value	7 - 22 m <sup>3</sup> /h
Temperature	130 °C
Medium	Liquids and Gases

### Description

Self-acting pressure reducers are simple control valves offering accurate control while being easy to install and maintain. They control the pressure downstream of the valve without requiring pneumatic or electrical control elements.

The DM 586 pressure reducing valve is a diaphragm-controlled, spring-loaded and balanced proportional control valve for high flow rates especially for the control of millibar ranges. This pressure reducer is manufactured from deep-drawn stainless steel featuring excellent corrosion resistance. The valve cone is fitted with a soft seal.

The outlet pressure to be controlled is balanced across the control unit by the force of the valve spring (set pressure). As the outlet pressure rises above the pressure set using the adjusting screw, the valve cone moves towards the seat and the volume of medium is reduced. As the outlet pressure drops, the valve control orifice increases; when the pipeline is depressurised, the valve is open. Rotating the adjusting screw clockwise increases the outlet pressure.

These valves are no shut-off elements ensuring a tight closing of the valve. In accordance with DIN EN 60534-4 and/or ANSI FCI 70-2 they may feature a leakage rate in closed position in compliance with the leakage classes V (soft seal cone =  $1.8 \times 10^{-5} \times \Delta p \times D^*$  [l/h], \*D=seat diameter).

### Standard

- » all stainless steel construction
- » non rising adjusting screw
- » sense line connection
- » balanced cone for controlling the outlet pressure independently from the inlet pressure

### Options

- » pressure gauge connection
- » pneumatic actuation
- » for toxic or hazardous media: sealed spring cap complete with leakage line connection (incl. sealed adjusting screw). Must be installed with a leakage line capable of draining leaking medium safely and without pressure
- » various diaphragm and seal materials suitable for your medium
- » special connections: Aseptic, ANSI or JIS flanges, NPT, welding spigots; other connections on request
- » special versions on request

Operating instructions, know how and safety instructions must be observed. All the pressure has always been indicated as overpressure. We reserve the right to alter technical specifications without notice.



### K<sub>vs</sub> values [m<sup>3</sup>/h]

nominal diameter	G	3/4	1	1 1/2	2
	DN	20	25	40	50
K <sub>vs</sub> value	m <sup>3</sup> /h	7	8	22 (8*)	22 (8*)

\* option

### Setting Ranges [bar], Nominal Pressure

0,008 - 0,03	0,02 - 0,12	0,1 - 0,65	0,3 - 0,95
PN 16/1	PN 16/1	PN 16/1	PN 16/2,5

### Reduction Ratio (max. p<sub>1</sub>/p<sub>2</sub>)

setting range [bar]	K <sub>vs</sub> value [m <sup>3</sup> /h]		diaphragm ø [mm]
	7 + 8	22	
0,008 - 0,03	600	375	360
0,02 - 0,12	350	350	360
0,1 - 0,65	300	300	200
0,3 - 0,95	170	170	200

# Pressure Control Valves

## Pressure Reducing Valves DM 586

Millibar Control Valve for High Flow Rates



Materials	
Temperature	130 °C
Body, Spring Cap, Internals, Screws	CrNiMo-steel
Spring	CrNi-steel
Valve Seal	EPDM or FKM
Diaphragm	EPDM optional FKM
Protection Foil	PTFE (option)

Dimensions [mm]							
setting ranges bar	size	nominal diameter / $K_{vs}$ value					
		G 3/4 DN 20	G 1 DN 25	G 1 1/2 DN 40		G 2 DN 50	
all ranges	A	91	85	145	145	185	185
	A <sub>1</sub>	150	160	200	200	230	230
	B	76	76	76	80	76	80
	C	305	305	305	305	305	305
0.008 - 0.03	D	360	360	360	360	360	360
0.02 - 0.12		360	360	360	360	360	360
0.1 - 0.65		264/210	264/210	264/210	264/210	264/210	264/210
0.3 - 0.95		264/210	264/210	264/210	264/210	264/210	264/210

Weights [kg]				
setting ranges bar	nominal diameter G			
	3/4	1	1 1/2	2
0.008 - 0.03		14,5		
0.02 - 0.12		14,5		
0.1 - 0.65	8,5			
0.3 - 0.95	8,5			

Weights[kg]				
setting ranges bar	nominal diameter DN			
	20	25	40	50
0.008 - 0.03			17	20
0.02 - 0.12			17	20
0.1 - 0.65	10,5	11	13,5	15
0.3 - 0.95	10,5	11	13,5	15

**Customs Tariff Number**  
84811019

Special designs on request.  
The pressure has always been indicated as overpressure.  
Mankenberg reserves the right to alter or improve the designs or specifications of the products described herein without notice.

### Dimensional Drawing

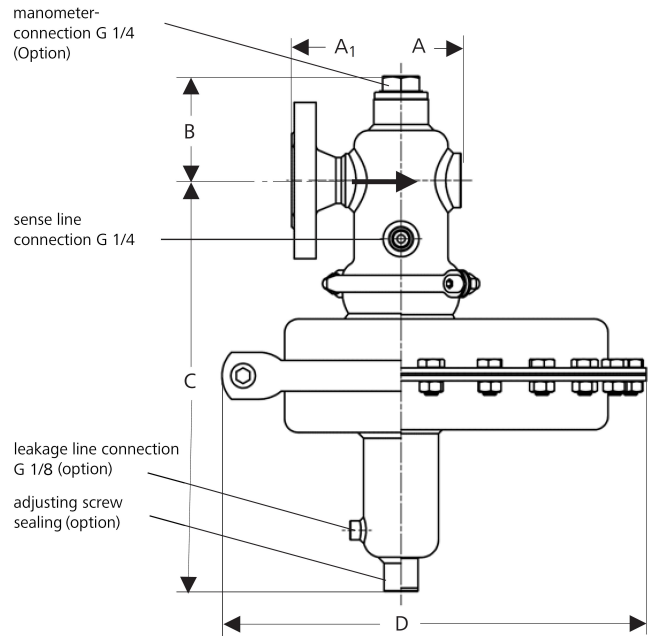

### Recommended Installation

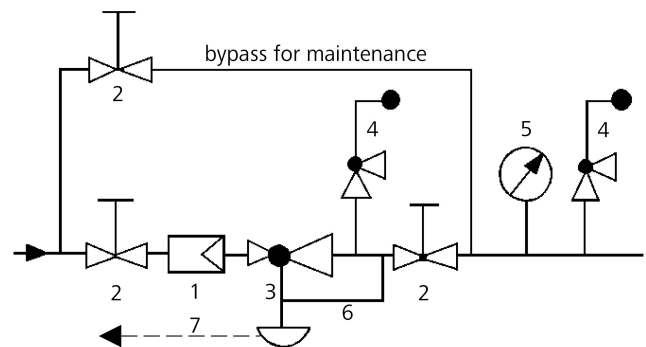

- 1 Strainer
- 2 Shut-off Valves
- 3 Pressure Reducer
- 4 Safety Valves
- 5 Pressure Gauge
- 6 Sense Line G 1/4
- 7 Leakage Line G 1/8 (option)

sense line connection 10 - 20 x DN behind the valve  
use MANKENBERG-Products